



GUYSON



Standard Rotary Spindle
& Table Blast Systems (RSB)

guyson.co.uk

Introduction



Guyson International Limited is a privately owned family company with a world-wide reputation for excellence in the design and manufacture of robot, automated and manual blast finishing, shot peening, spray wash and ultrasonic cleaning systems.

Founded over 85 years ago (Est May 20th 1938) Guyson Industrial Equipment Limited began as a distributor of garage equipment as well as manufacturing small sand blast cabinets. In 1972 the company was re-named 'Guyson International Limited' to better reflect the company's export success and increasing overseas interests. Through acquisition - Marr Engineering (1996) and Kerry Ultrasonics (2004) - Guyson has enhanced our product offering incorporating spray wash, ultrasonic and solvent cleaning systems to a comprehensive range of blast systems.



Guyson continues to innovate and invest offering unrivalled support for our existing and new customers across the globe. With headquarters in Skipton North Yorkshire, the Guyson Blast & Wash group consists of: Guyson Corporation, Saratoga Springs USA; Guyson SA, Chambly, France; Guyson Sdn Bhd, Penang, Malaysia; and Guyson CN, Wuxi, China. With a growing network of distributors and re-sellers Guyson provides class leading cleaning and surface finishing solutions across any market sector, anywhere in the world.





Over the last 85 plus years we have honed our knowledge and experience of a huge variety of applications for our products, and along with our customers we are still finding innovative and ingenious ways to create the perfect finish. We work across a vast range of industries at all levels from hobbyists and sole-traders to some of the world's largest companies, we like to think we have the right Guyson Solution whatever the process or application.

With such a wide range it is important that we make the right choice. That's why our free sample evaluation service, open to anyone, has always been a cornerstone of our business. We work hard to make sure you get the best solution, from initial sample evaluation, witness tests and factory acceptance tests all the way through to installation, maintenance and operator training.

Manual Blast



Formula - Entry level blast cabinets



Euroblast - Industrial blast cabinets



Euroblast SBP - Seated blast cabinet



Mediblast - Stainless steel blast cabinet



Euroblast GL - Flat glass blast cabinet

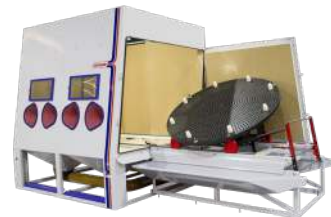

Euroblast - Extra large blast cabinets

Automated Blast



Tumbleblast - Batch load rotary basket systems



Multiblast RSB - Rotary spindle blast systems



Multiblast RXS900 - Rotary indexing blast systems



RB - Robotic blast systems



In-Line Automated Blast Systems

Ultrasonic & Wash



Guyson - Benchtop ultrasonic baths



UCR - Ultrasonic wash & rinse baths



CRD 450 - Wash, rinse & dry



Microsolve - Solvent cleaning systems



Microclean - Multi-stage ultrasonic cleaner

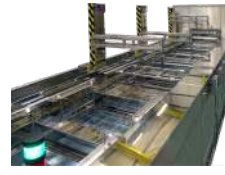

Supercleaner - Multi-stage aqueous ultrasonic cleaner

Rotary Spindle & Table Blast Systems



Guyson's Rotary Spindle & Table Blast Systems (RSB) deliver consistent and effective finishing results that add value to your components. The RSB is of a modular design, with flexibility for either fixed guns or transversing guns (horizontal or vertical inverter controlled driven gun drive options), and a spindle or turntable fixture.

The Multiblast RSB model comes with a suction feed system, and is complemented with a cyclone separator and dust collector that matches the needs and size of the application.

As standard, the Multiblast RSB comes with four Guyson Model 900 guns, allowing optimum blast coverage of components on the table.

Typical applications for Guyson's Multiblast RSB systems:

- Deburring and surface preparation of turbochargers
- Aerospace MRO
- Surface preparation of seal rings
- Surface preparation of medical implants (hips, knees)
- Etching steering arms prior to bonding.
- Preparation of tooling prior to PVD coating





Rotary Spindle & Table Blast Systems

Standard RSB Features

- PLC/HMI Electrical controls housed in the upper RHS panel
- Pneumatics housed in the lower RHS panel
- 1" BSP connection for compressed air
- Single pressure regulator for all four guns
- Individual solenoids for each gun
- Flow regulator & individual solenoid for airwash
- Low air pressure switch
- Two ES bulkhead lights fitted with LED E27 9W 6000k 230V bulbs
- Hanging rubber curtains on the sides and back of the cabinet
- Bonded rubber on back of the door
- Hopper elbow 100mm diameter for connection to cyclone
- Four fixed 900 guns on adjustable arms
- One fixed airwash (900 gun 4.8mm airjet), on adjustable arm
- *Spindle only*: delivers 28rpm at the spindle variable by inverter control
- All spindle and table variations come with;
 - CY600/12 cyclone with level sensors for media and dust separation
 - C800 twin cartridge dust collector with reverse pulse compressed air cleaning, primary filter and HEPA14 status magnehelic gauges, and a 40L waste bin

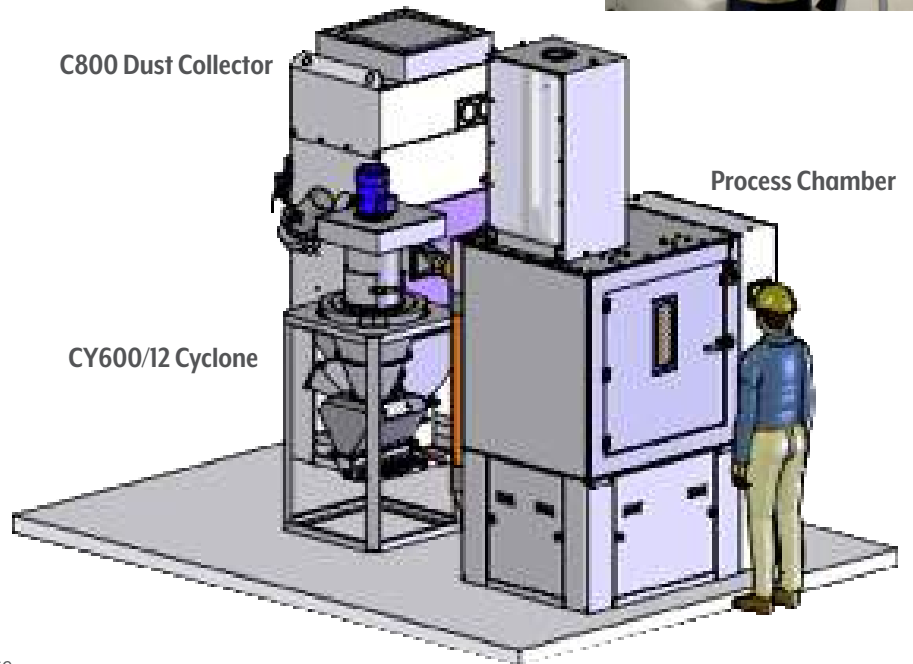

Standard RSB Dimensions

Cabinet overall dimensions	1510mm (wide) x 1300mm (deep) x 1990mm (high)
Front loading door	874mm (wide) x 874mm (high)
Maximum part dimensions to be blasted, including any fixture approx.	300mm (diameter) x 450mm (high)
Maximum weight on spindle, including any fixture	20kg
Maximum weight on table, including any fixture	100kg
Spindle RPM	14 - 56 rpm

RSB Configurations

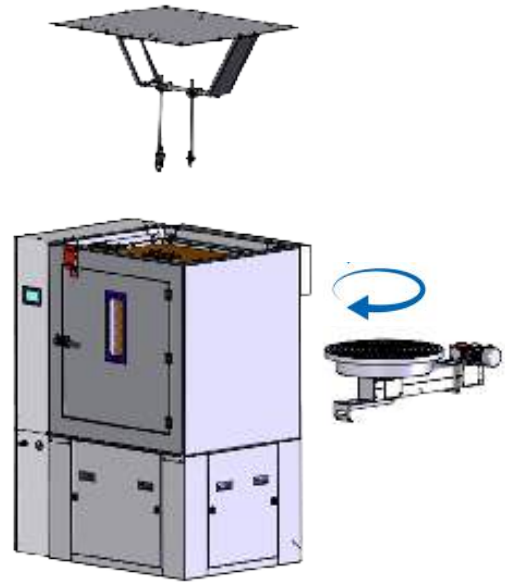

RSB - Turntable & Fixed Gun Drive

Turntable	750mm (diameter)
Maximum part dimensions to be blasted, including any fixture approx.	600mm (diameter) x 450mm (high)
Maximum weight on table, including any fixture	100kg
Optional speed range	1.7 to 6.7 rpm ; or 3.5 to 7 rpm
Table RPM	3.5 - 14 rpm

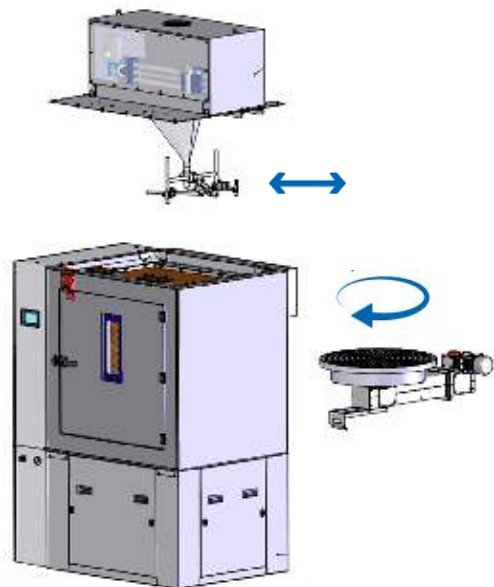
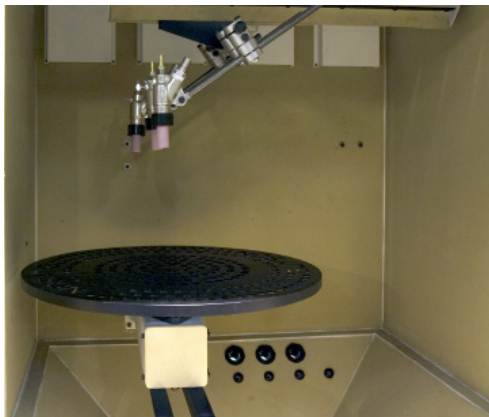

RSB - Turntable & 4 Horizontal Gun Drives

Turntable	750mm (diameter)
Maximum part dimensions to be blasted, including any fixture approx.	600mm (diameter) x 300mm (high)
Maximum weight on table, including any fixture	100kg
Horizontally traversing gun drive (900 guns, on adjustable arms)	350mm stroke & 5mm pitch screw
One horizontally moving airwash	4.8mm airjet, on adjustable arm
Horizontal traverse speed range	70mm/min to 280mm/min
Table RPM	3.5 - 14 rpm



RSB Configurations

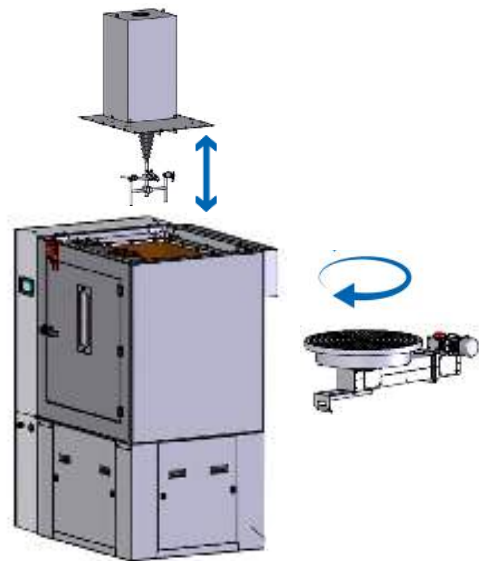

RSB - Turntable & 4 Vertical Gun

Turntable	750mm (diameter)
Maximum part dimensions to be blasted, including any fixture approx.	600mm (diameter) x 450mm (high)
Maximum weight on table, including any fixture	100kg
Vertically traversing gun drive (900 guns, on adjustable arms)	350mm stroke & 5mm pitch screw
One vertically moving airwash	4.8mm airjet, on adjustable arm
Vertical traverse speed range	240mm/min to 470mm/min
Table RPM	3.5 - 14 rpm

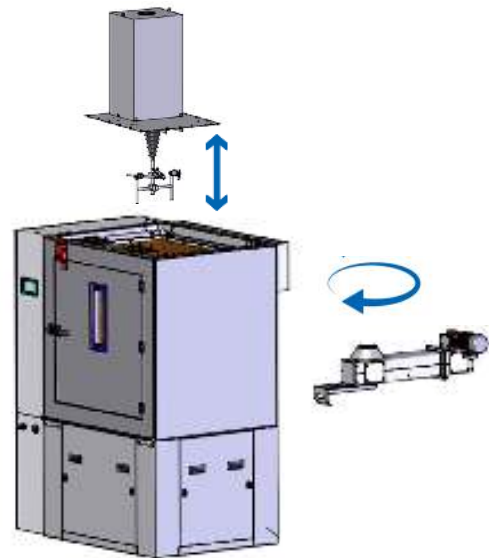

RSB - Rotating Spindle & 4 Vertical Gun

Maximum part dimensions to be blasted, including any fixture approx.	300mm (diameter) x 450mm (high)
Vertically traversing gun drive (900 guns, on adjustable arms)	350mm stroke & 5mm pitch screw
One vertically moving airwash	4.8mm airjet, on adjustable arm
Vertical traverse speed range	240mm/min to 470mm/min
Spindle RPM	14 - 56 rpm

Test & Demonstration



Here at Guyson we understand that choosing the right equipment for the job is a process critical decision which is why we insist on comprehensive sample evaluation prior to recommending any of our systems. We have always offered a free sample evaluation service and ensure we can provide the best possible advice and recommendations on media type, equipment selection and process considerations.



With more than 80 years of experience and one of Europe's largest test and evaluation facilities, Guyson provides unrivalled level of process qualification, recommendation and operator training.

Contact us today to get your components evaluated, book a demonstration or just simply take a tour.





Spares, Media & Services

Products

Established in 1938, Guyson International Limited is a privately owned family company with a world-wide reputation for excellence in the design and manufacture of robot, automated and manual blast finishing, spray wash and ultrasonic cleaning equipment. Guyson International manufacture, assemble and test in the UK to the latest ISO 9001:2015 quality and ISO 45001:2018 Occupational Health and Safety Management standards.

Customer Service

Guyson don't just manufacture and supply products, our dedicated customer service team are available to provide our customers with the best possible aftersales care. From advice and guidance on equipment selection and operation to the identification of spares or blast media our customer service team have over 80 years of experience to ensure your Guyson equipment is operating at its optimum level.



Spares

We hold extensive stocks of consumables and wear parts in support of all our equipment. Based at our Skipton head office our dedicated aftersales team are perfectly placed alongside our design, service, test and manufacturing teams to advise and help identify spares for machines dating back for 30+ years. With collection or next day delivery available, Guyson is best placed to provide peace of mind ensuring your Guyson equipment continues to run efficiently.

Blast Media

Guyson are experts in the selection and supply of all types of blast media. From our test and demonstration facility we provide a free sample evaluation service and can advise you on the best possible media for your application. With over 60 types and sizes of blast media in stock and a wide range of specialist options available to order Guyson is your first choice for quality and service.

Service

All Guyson equipment comes with 12 months comprehensive warranty as standard. With operator and maintenance training available when your machine is delivered, customer service support over the phone and a team of Specialist Field Service Engineers to install and commission your equipment, Guyson delivers peace of mind.

To ensure your Guyson equipment continues to run smoothly our dedicated service team can offer a comprehensive range of service packages. From preventative maintenance and service agreements to breakdown, repair and refurbishment, Guyson strive to ensure your investment stays as productive as possible for as long as possible.

For more information on sample evaluation, training, media, spares and our range of services packages visit our website or contact your nearest Guyson location, details on the back of this brochure.



Designed & Manufactured
in the UK since 1938



Products

Manufacturers of Blast Finishing, Peening,
Ultrasonic & Spray Wash Systems



Customer Service

After Sales, Spares and Blast Media, Sample
Evaluation, Training & Demonstration



Service

On Site Installation, Commissioning,
Preventative Maintenance, Service and Repair

Industries

Guyson covers all market sectors and specialise in:



Automotive



Aerospace



Medical

Distributed by:

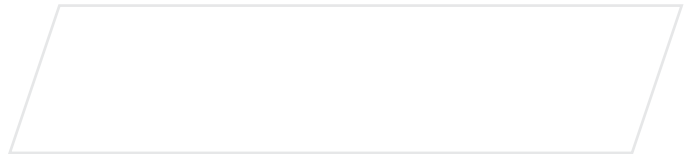

Contacts

UK

Sales, Design and
Manufacturing Centre

Guyson International Ltd.

Snaygill Industrial Estate
Keighley Road
Skipton, North Yorkshire
BD23 2QR

T: +44 (0)1756 799911

E: info@guyson.co.uk

www.guyson.co.uk

France

Sales and Service Centre

Guyson SA

ZAC des Portes de l'Oise
2 rue Henri Becquerel
Bâtiment B7
60230 Chambly, France

T: +33 (0)1 30 28 43 16

E: contact@guyson.fr

www.guyson.fr

USA

Design and Manufacturing
Centre

**Guyson Corporation of
USA**

W.J. Grande Industrial Park
13 Grande Blvd.
Saratoga Springs
NY 12866-9090

T: +1 518 587 7894

E: info@guyson.com

www.guyson.com

Malaysia

Sales and Service Centre

Guyson SDN BHD

3, S-08-03, Persiaran
Kelicap Setia Tri-Angle
11900 Bayan Lepas

Malaysia

T: +60 46 03 73 62

E: kerry@guyson.co.uk

China

Sales and Service Centre

Guyson SDN BHD

Wuxi Representative Office
28# Building, ZhenXin Road
Xing An, New District

Wuxi

Jiangsu Province

P.R. China

Postal code: 214000

T: +86 510 82790120

E: zhlzhy@guyson.co.uk

